

ABOUT US

**We do not follow quality, we direct it.
Quality is our essential.**

PB Foreign Trade is the export company of Premier Business Group, specialized in manufacturing aluminium extruded profiles & composite panels. We are a leading provider of economical, high quality aluminium extrusion solutions. For two decades, we have pioneered the standards for products ranging from basic mill finish profiles to the most complex curtain wall systems. Ideally situated in Istanbul, PB Foreign Trade presents a unique and productive sourcing opportunity for European and African customers, and certainly welcomes clients from Asia, as well. Thanks to our high technology steps in the aluminium sector and our principle of responding through our experienced staff, we actually are located in foreign markets with more than 13.000 customized dies. Across Europe, we combine the benefits of local support with access to world-class equipment and prime aluminium billet. The proximity of our factory operations (thanks to special custom union agreement with E.E.U) ensures unmatched economies for our customers all without sacrificing quality. These are supported by;

- TSE (Turkish Standards Institute Quality Certificate for extrusions and anodizing)
- EURAS/EWAA (Quality Certificate of European Anodizers Association/European Wrought Aluminium Association by Qualanod International)
- ISO 9001 and ISO 9002 certificates

Quality at PB Foreign Trade starts with use of prime aluminium billet. It extends to our highly trained and dedicated engineers and staff, and a professional management team that oversee your project at every stage, and with whom you have direct communication. The profiles that we have been producing are being used in nearly 40 different sectors from doors-windows to accessories from ventilation systems to roller blinds. Anodisation, powder coating, cutting, drilling, punching facilities are available in our plant.

Our fully integrated production facility operates on a total area of 119,000 m² in Sakarya, Turkey. There are 7 extrusion presses with a capacity of 70.000 tons/year, an anodizing facility with a capacity of 30.000 tons/year, vertical powder coating facilities with a capacity of 35.000 tons/year, a wood transfer paint unit with a capacity of 1.500 tons/year, and an aluminium composite panel production capacity of 4.500.000 m²/year in our plant.

Our motto is to produce European quality with reasonable prices. We can offer you very competitive prices and attractive delivery times to your own profiles in case you send us their technical drawings or the samples with all necessary information such as alloy, surface treatment, any mechanical processing, length and quantity.

By analyzing the expectations of its customers; having experience in customer-oriented product development, our factory works with all its strength to supply many products that are not included in the sales portfolio and to meet the expectations of its customers 100%.

Our factory, which is among the Top 500 Industrial Enterprises of Turkey today, also takes its place among the Top 1000 Exporters of Turkey since 2004. With 900 employees and exports to more than 30 countries, it is one of the leading companies in the sector that contributes to the Turkish economy.

Aluminium profile production, aluminium billet production, aluminium composite panel production, aluminium-plastic accessories sales are the main fields of activity of the company. One of our main goals is to support our economy with 900 people working within the facility. Our expert and experienced marketing team works in order to meet all the needs of our customers at a single point. PB family has adopted the principle of increasing customer satisfaction by continuously improving the product quality and performance expectations of its customers with an innovative approach.

INDEX

ALÜMİNYUM KAPI VE PENCERE MENTEŞELERİ	5
ALÜMİNYUM KAPI VE PENCERE KOLLARI	6
ALÜMİNYUM PENCERE VASİTAS ÇARPMA VE MAKASLARI	12
ALÜMİNYUM KAPI VE PENCERE SÜRGÜLERİ	14
ALÜMİNYUM KAPI KİLİTLERİ	15
MONTAJ VİDALARI	18
ALÜMİNYUM ÇİFT AÇILIM	20
ALÜMİNYUM KAPI VE PENCERE YAPIŞTIRICILARI	22
ALÜMİNYUM KAPI VE PENCERE KÖŞE BAĞLANTILARI	24
ALÜMİNYUM SÜRME AKSESUARLARI	28
ALÜMİNYUM KAPI VE PENCERE PLASTİK CAM TAKOZLARI	30
ALÜMİNYUM KAPI VE PENCERE SİNEKLİK AKSESUARLARI	32
PLASTİK KAPI VE PENCERE AKSESUARLARI	34
ALÜMİNYUM KAPI VE PENCERE FİTİLLERİ	38
ALÜMİNYUM KAPI HİDROLİĞİ CAM DETAY VE PASLANMAZ KAPI KOLLARI AKSESUARLARI	40
MATKAP UÇLARI VE ELMAS TESTERELER	41
MATKAP EL ALETLERİ	44
HIRDAVAT EL ALETLERİ	48
ALÜMİNYUM VE PVC MAKİNALARI	53

**01 010801**C 60 YAPRAK
MENTEŞE ELOKSALLI**01 010701**C 60 TAKOZLU
MENTEŞE ELOKSALLI**01 010501**C 60 BABA
MENTEŞE ELOKSALLI**01 012206**YAYLI MENTEŞE
NO: 33 SATEN**01 012101**YAYLI MENTEŞE ALM
NO: 33 KADYUMLU**01 010201**DÜZ ALDOKS
MENTEŞE ELOKSALLI**01 010301**ALDOKS GEÇME
MENTEŞE ELOKSALLI**01 010905**ALDOKS BURSA
MENTEŞE ELOKSALLI**01 010401**BİNME
MENTEŞE**01 010901**İZO PENCERE
MENTEŞE ELOKSALLI**01 011101**İZO KAPI
MENTEŞE ELOKSALLI**01 011001**İZO ÜÇGEN PİVOT
MENTEŞE ELOKSALLI



ALÜMİNYUM KAPI VE PENCERE MENTEŞELERİ

ALÜMİNYUM KAPI VE PENCERE KOLLARI



01 011301

Y.S 2 Lİ
MENTEŞE ELOKSALLI



01 011601

Y.S 3 LÜ
MENTEŞE ELOKSALLI



01 011120

AYARLI SİSTEM
KAPI MENTEŞESİ



01 031901

LAMA BANT KOL
90 cm - 100 cm ELOKSALLI



01 160103

KDO40/30-280 B
KALE PANİK BAR BARELSİZ



01 160106

KDO40 30-291
KALE PANİK BAR KOLU
(KİLİTLENEBİLİR)

ALÜMİNYUM KAPI VE PENCERE KOLLARI



01 031309

50cm| H
KOL ELOKSALLI

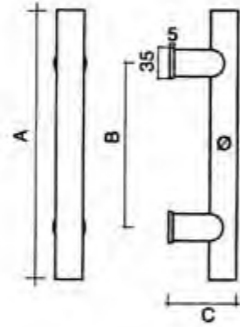

H-KOL

		A	B	C
H30S060	30	400	200	75
H30S060	30	500	300	75
H30S120	30	800	500	75
H30S150	30	1000	700	75

*'A' ve 'B' istenen ölçülerde üretilebilir.
*'A' ve 'B' can be produced in desired dimensions.



01 031201

50cm
YAY KOL ELOKSALLI

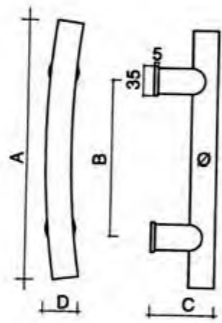

YAY KOL

		A	B	C	D
H30S050	30	500	420	85	85
H30S080	30	800	720	100	100

*'A' ve 'B' istenen ölçülerde üretilebilir.
*'A' ve 'B' can be produced in desired dimensions.



01 031101

AK 2025
KAPI KOLU ELOKSAL



01 031104

AKBANK
KOL APARATI



U KOL

	Ø	MM
U20A010	20	100
U20A015	20	150
U25A020	25	200
U25A030	25	300
U25A035	25	350
U25A040	25	400

01 051101

25 MM 30 CM
U KOL ELOKSALLI



KIVRIK KOL

	Ø	MM
K20A015	20	150
K25A020	25	200
K25A030	25	300
K25A040	25	350
K25A050	25	400

01 030401

25 MM 30 CM
KIVRIK KOL ELOKSALLI



01 031350

50cm
KÖŞELİ H KOL ELOKSALLI



01 030901

YARIM AY KAPI KOLU
ELOKSALLI

01 031820

 AYNALI KIVRIK D KOL
ELOKSALLI

01 020302

 YENİ İSPANYOLEK
KOL B.BOYALI

01 020550

 GİZLİ CEPHE KANAT KOLU
NATUREL BOYALI

01 020803

 FORZA EKSENEL PENCERE KOLU
NATUREL BOYALI

01 200291

 ROTOLİNE SECUSTİK
PENCERE KOLU

01 040701

 ROZETSİZ SOSİS KOL
ELOKSALLI

01 100400

 DIŞ CEPHE KOLU
ELOKSALLI

01 021203

 EURO EKSENEL KOL
TEK DİLLİ

01 100409

 EURO GIESSE CEPHE KOLU
GRİ

01 040104

 YAYLI ROZETLİ
SOSİS KOL

01 040101

 ROZETLİ SOSİS KOL
ELOKSALLI

01 031701

 10 CM KARE KOL
ELOKSALLI

01 020601

 R29W ROTOLİNE
EKSENEL KOL

01 071012

 İZO SÜRME
PARİZYEN KOL

01 020810

 FORZA ÇİFT DİLLİ EKSENEL
PENCERE KOLU NATURAL

Dar ve geniş olarak seçenekleri mevcuttur.

01 040120

 GENİŞ AYNALI
SOSİS KOL

01 031801

 D ÇEKME KOL
ELOKSALLI

01 120300

 KÖR SOMUNLU
SAPLAMA

01 020501

 EKSENEL İSPANYOLEK KOL
ELOKSALLI AK-340

01 020604

 ROTOLİNE ALÜ. KİLİTLİ KOL.
NATUREL

01 040904

 YAYLI KİLİTLİ KOL METAL
FORZA NATUREL BOYALI

01 032001

 C KOL
ELOKSALLI

01 050301

 YAYLI TETİK KOL
ELOKSALLI

01 050305

 KİLİTLİ TETİK KOL
ELOKSALLI



01 050401

TUBA ÇEKME HAVUZ KOL
ELOKSALLI



01 050705

BRİO HAVUZ KOL
NATUREL



05 011502

DSL 7910
SÜRME KOL GRİ



05 011510

DSL 7901
SÜRME KOL KİTİ



01 120600

PLS KİT-AL
AKSESUAR





ALÜMİNYUM PENCERE VAŞİSTAS ÇARPMA VE MAKASLARI



01 080101

13 CM VASİSTAS MAKASI
ELOKSALLI



01 080201

22 CM VASİSTAS MAKASI
ELOKSALLI



01 080301

13 CM İZO VASİSTAS MAKASI
ELOKSALLI



01 080401

22 CM İZO VASİSTAS MAKASI
ELOKSALLI



01 081400

VASİSTAS MAKASI
ÇELİK

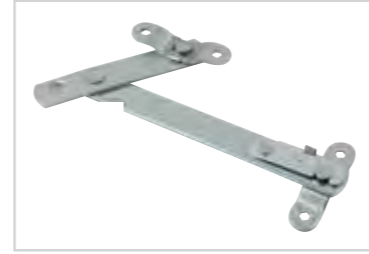

01 080500

13 CM İZO SAC
VASİSTAS MAKASI



01 081000

AYARLI KADEMELİ
MAKAS



01 100301

CEPHE MAKASI GSHD 10"
700-1200 HD

CEPHE MAKASI

HD 10"	700-1200
HD 12"	800-1200
HD 14"	1000-1300
HD 16"	1200-1400
HD 18"	1400-1400
HD 20"	1600-1500
HD 22"	1700-1500
HD 24"	1800-1500
HD 26"	2100-1800
HD 28"	2000-1500



01 081501

VASİSTAS ÇARPMA
ELOKSALLI



01 081704

ALM. AYARLI VASİSTAS ÇARPMA
RENKLİ



01 060201

C 60 KİLİT KARŞILIĞI
ELOKSALLI

ALÜMİNYUM PENCERE VAŞİSTAS ÇARPMA VE MAKASLARI



01 060101

KİLİT KARŞILIĞI
ELOKSALLI



01 060301

İZO KİLİT KARŞILIĞI
ELOKSALLI



01 060210

OVAL SERİ
KİLİT KARŞILIĞI



01 070501

 SAVYO SÜRGÜ
ELOKSALLI

01 070103

 UFAK ZAMAK SÜRGÜ
GRİ BOYALI

01 070301

 GÖMME SÜRGÜ
ELOKSALLI

01 070601

 C 60 ÇİFT PİMLİ SÜRGÜ
ELOKSALLI

01 070203

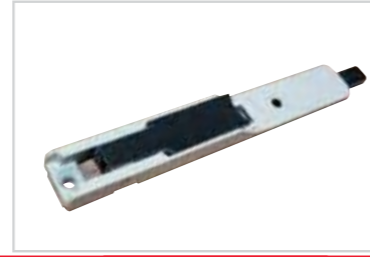
 UZUN ZAMAK SÜRGÜ
RENKLİ

01 070153

 EURO ZAMAK SÜRGÜ
KISA NATUREL B.

01 070401

 FİŞEK SÜRGÜ
ELOKSALLI

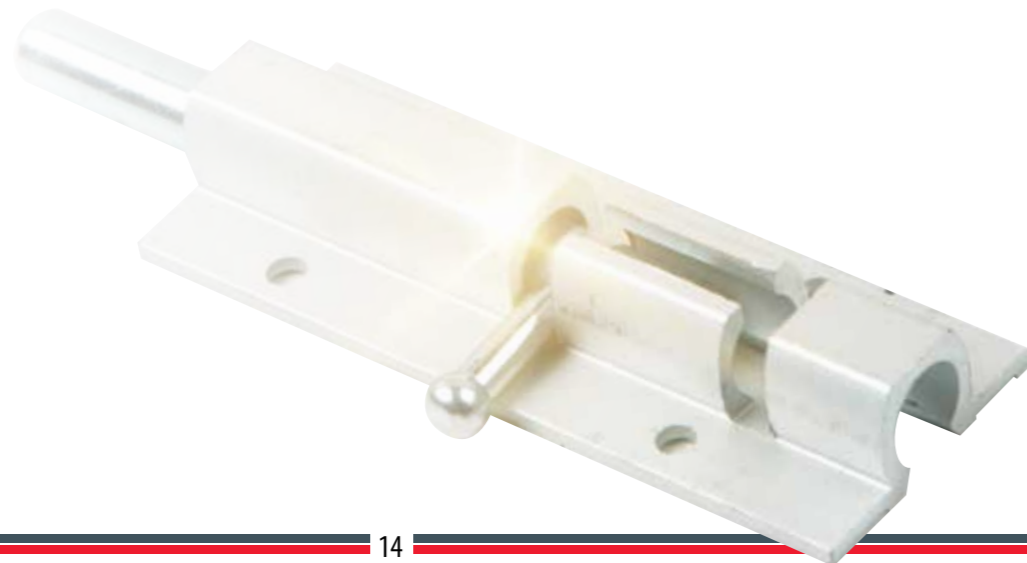
01 071100

 03203-00 Y.S
FİŞEK SÜRGÜ

05 010200

 155/20 U KALE SÜPER
S.MAKARALI (KİLİT)

05 010402

 155/20 U KALE SÜPER
S.MAKARALI (GÖVDE)

05 010109

 153/20 U KALE SÜPER
SİLİNDİRLİ DİLLİ (KİLİT)

05 011000

 153/20 U KALE SÜPER
SİLİNDİRLİ DİLLİ (GÖVDE)

05 010202

 154/ KALE SÜPER
S.MAKARALI (KİLİT) 35 mm

05 010100

 152/R KALE SÜPER
SİLİNDİRLİ (KİLİT) 35 mm

05 011400

 ELEKTRİKLİ KAPI KARŞILIĞI
KALE 222

05 010701

 157/F KALE FİAM EMN. KİL. 3
ANAHTARLI

05 010114

 201/F KALE SİLİNDİRLİ
SÜRME KİLİDİ 20 MM

05 010112

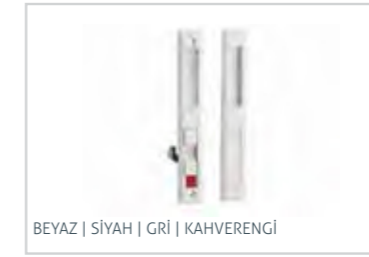
 201 KALE SİLİNDİRLİ
SÜRME KİLİDİ 20 MM

05 010901

 301/GRİ KALE PVC ALM.
SÜRME KİLİT

05 010905

 302/GRİ KALE PVC ALM.
SÜRME KİLİT



20 mm | 25mm | 30 mm | 35 mm

05 010308

269/PWC-20 KALE
PVC BANYO

05 010410

155/P 20 KALE MAKARALI
SİLİNDİRLİ PVC KİLİT

05 010303

153/P 20 SİLİNDİRLİ
PVC KİLİT



20 mm | 25mm | 30 mm | 35 mm

05 010406

269/WC 20 KALE ALM.
BANYO WC

05 010205

155/B KALE MAKARALI
ÇARPMA KİLİT

05 010415

TOROS 35x85
ALÜMİNYUM KİLİDİ

05 010708

189 3 MF KALE PRAZİS
FİYAM EMNİYET KİLİDİ

05 011200

165 KALE
KEPENK KİLİDİ

05 010609

357/MS KALE EL.
KAPI OTO. KİL. MAK. PAS.

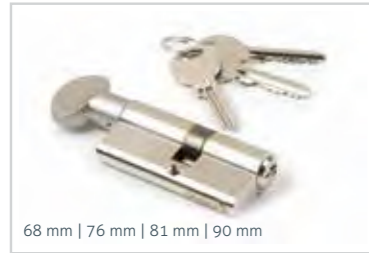

68 mm | 76 mm | 81 mm | 90 mm

05 011113

164/68 GMC KALE
SÜP.CER.MAND. BAR



62 mm | 68 mm | 76 mm | 81 mm | 90 mm

05 011101

164/62 GNC KALE
SÜP.CER. BAR.

05 011118

164/BNE KALE
BİLYALI BAREL 68 MM

05 011122

164/CEC TÜPTEN ŞİFRELI
SİLİNDİR 68 MM (26+10+32)
KUMLU NİKEL 5 ANAH.

05 010850

197F KALE FOTOSELLİ
KAPI EMNİYET KİLİDİ



83 mm | 100 mm

05 021207

TECMAT
BAREL

01 160108

KD040/35-320 KALE
TOPUZLU KİLİT (KİLİTLİ)

11 030414

KD-070/20-123 KALE
CAM KİLİDİ

11 030419

KD070/20-125 KALE CAM KAPI
EMNİYET KİLİDİ(ÇİFT KANAT)

11 030418

KD-070/30-100
KALE PARADUŞ MENTEŞE

11 030420

KD-070/20-124
KALE CAM KAPI EMNİYET KİLİDİ
(TEK KANAT)

YSB MATKAP UÇLU VİDA DIN 7504-N

ÖLÇÜ	KUTU MİKTARI	KOLİ MİKTARI
3.9X13	2.000	24.000
3.9X16	2.000	20.000
3.9X19	1.000	14.000
3.9X22	1.000	12.000
3.9X25	1.000	12.000
3.9X32	1.000	10.000
3.9X38	1.000	10.000
4.2X13	1.000	12.000
4.2X16	1.000	12.000
4.2X19	1.000	12.000
4.2X22	1.000	12.000
4.2X25	1.000	10.000
4.2X32	1.000	10.000
4.2X38	1.000	6.000
4.8X16	1.000	12.000
4.8X19	1.000	10.000
4.8X22	1.000	10.000
4.8X25	1.000	8.000
4.8X32	1.000	6.000
4.8X38	1.000	6.000
4.8X45	500	3.000
4.8X50	500	3.000
4.8X60	500	4.000
4.8X70	400	3.200
4.8X80	300	2.400
4.8X100	200	1.200

YILDIZ SİLİNDİR BAŞ

YSBMU

YHB MATKAP UÇLU VİDA DIN 7504-P

ÖLÇÜ	KUTU MİKTARI	KOLİ MİKTARI
3.9X13	2.000	28.000
3.9X16	2.000	20.000
3.9X19	2.000	20.000
3.9X22	1.000	14.000
3.9X25	1.000	12.000
3.9X32	1.000	10.000
3.9X38	1.000	10.000
4.2X13	2.000	24.000
4.2X16	2.000	20.000
4.2X19	2.000	16.000
4.2X22	1.000	12.000
4.2X25	1.000	10.000
4.2X32	1.000	10.000
4.2X38	1.000	10.000
4.2X45	1.000	8.000
4.2X50	1.000	8.000
4.8X16	2.000	20.000
4.8X19	1.000	12.000
4.8X22	1.000	10.000
4.8X25	1.000	10.000
4.8X32	1.000	6.000
4.8X38	1.000	6.000
4.8X45	1.000	6.000
4.8X50	750	6.000
4.8X60	500	4.000
4.8X70	400	3.200
4.8X80	300	2.400
4.8X100	200	1.200

YILDIZ HAVŞA BAŞ

YHBMU

YSB SAC VİDALARI DIN 7981

ÖLÇÜ	KUTU MİKTARI	KOLİ MİKTARI
3.9X13	1.000	12.000
3.9X16	1.000	12.000
3.9X19	1.000	14.000
3.9X22	1.000	12.000
3.9X25	1.000	12.000
3.9X32	1.000	10.000
3.9X38	1.000	6.000
4.2X13	1.000	12.000
4.2X16	1.000	14.000
4.2X19	1.000	12.000
4.2X22	1.000	10.000
4.2X25	1.000	10.000
4.2X32	1.000	10.000
4.2X38	500	5.000
4.2X45	1.000	6.000
4.2X50	500	5.000
4.8X13	1000	8.000
4.8X16	1000	8.000
4.8X19	1000	8.000
4.8X22	1000	10.000
4.8X25	1000	10.000
4.8X32	1000	6.000
4.8X38	500	5.000
4.8X45	500	3.000
4.8X50	500	3.000
4.8X60	500	3.000
4.8X70	350	2.100
4.8X80	300	1.800

YILDIZ SİLİNDİR BAŞ

YSB

YILDIZ HAVŞA BAŞ

YHB

YHB SAC VİDALARI DIN 7982

ÖLÇÜ	KUTU MİKTARI	KOLİ MİKTARI	ÖLÇÜ	KUTU MİKTARI	KOLİ MİKTARI
3.9X13	1.000	12.000	4.2X45	1.000	6.000
3.9X16	1.000	12.000	4.2X50	500	5.000
3.9X19	1.000	12.000	4.8X13	1000	12.000
3.9X22	1.000	14.000	4.8X16	1000	8.000
3.9X25	1.000	12.000	4.8X19	1000	8.000
3.9X32	1.000	10.000	4.8X22	1000	10.000
3.9X38	1.000	10.000	4.8X25	1000	10.000
4.2X13	1.000	12.000	4.8X32	1000	6.000
4.2X16	1.000	12.000	4.8X38	500	5.000
4.2X19	1.000	12.000	4.8X45	500	5.000
4.2X22	1.000	12.000	4.8X50	500	3.000
4.2X25	1.000	10.000	4.8X60	500	3.000
4.2X32	1.000	10.000	4.8X70	400	2.400
4.2X38	1.000	6.000	4.8X80	300	1.800

BETON MONTAJ VİDALARI

ÖLÇÜ	KUTU MİKTARI	KOLİ MİKTARI
7.5X60	200	2.000
7.5X80	150	1.500
7.5X100	100	1.000
7.5X120	100	1.000
7.5X150	100	800
7.5X180	100	500
7.5X200	100	600

BULDEX VİDA

 BETON MONTAJ
DÜBELSİZ VİDA

İSPANYOLET VİDALARI (HI-LO)

ÖLÇÜ	KUTU MİKTARI	KOLİ MİKTARI
3.9X19	2.000	20.000
3.9X22	1.000	14.000
3.9X25	1.000	12.000
3.9X32	1.000	10.000
3.9X38	1.000	10.000
4.2X32	1.000	10.000
4.2X38	1.000	10.000
4.2X45	1.000	6.000

İSPANYOLET VİDA

 SEYREK DİŞ VİDA
YHB

POP PERÇİN

EBAT	TİP
4x8	POP PERÇİN
4x10	POP PERÇİN
4x12	POP PERÇİN
4x15	POP PERÇİN
4x18	POP PERÇİN
5x10	POP PERÇİN
5x12	POP PERÇİN
5x18	POP PERÇİN
5x20	POP PERÇİN

POP PERÇİN

GÖMLEKLİ ÇELİK DÜBELLER

ÖLÇÜ	BOY	ÇAP	PAKET ADEDİ	KOLİ ADEDİ
M - 10x85	85 mm	15 mm	50	300
M - 10x110	110 mm	15 mm	50	300

ÇELİK DUBELLER

ÇİVATA GRUBU

EK BİLGİLER

ADDITIONAL INFORMATION

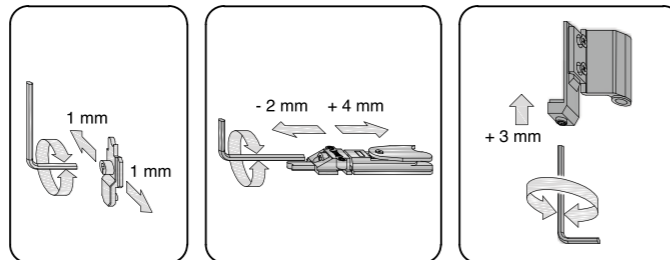
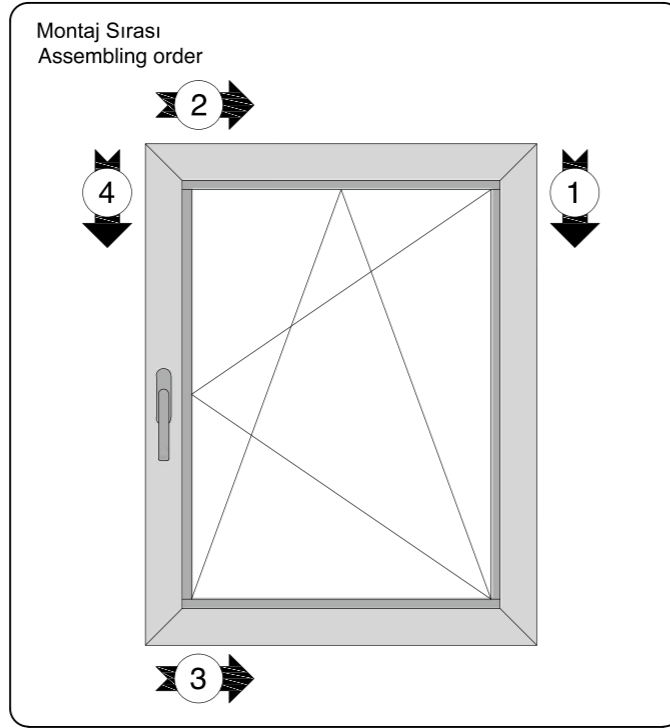
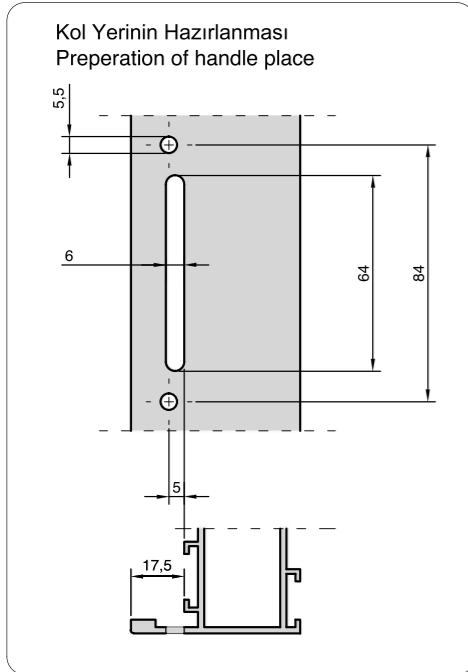
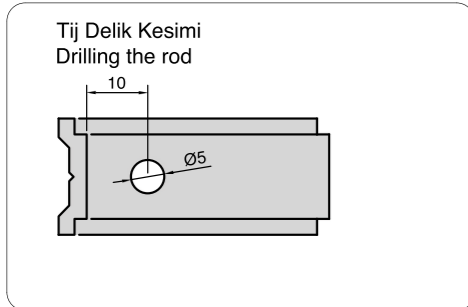

Teknik Özellikler

	300 Makas	435 Makas
Kanat genişliği:	minimum : 390 mm maksimum : 522 mm	minimum : 522 mm maksimum : 1700 mm
Kanat yüksekliği:	minimum : 600 mm maksimum : 2400 mm	minimum : 600 mm maksimum : 2400 mm

En fazla kanat ağırlığı: 80 kg

Technical Features

	300 Arm	435 Arm
Sash width:	minimum : 390 mm maksimum : 1700 mm	minimum : 522 mm maksimum : 1700 mm
Sash height:	minimum : 600 mm maksimum : 2400 mm	minimum : 600 mm maksimum : 2400 mm

Maximum sash weight: 80 kg

Boyanacak Parçalar için
Yapılacak Uygulama

- Boya kalınlığı 40~60 µm arasında olmalıdır.
- Vida dişleri ve pim delikleri boyadan korunmalıdır.
- Pencere kolunun boyanması işlemi 200°C'yi ve 15 dk.'yı aşmamalıdır.

Application for the parts
to be painted

- The paint thickness should be between 40~60 µm.
- Threads and pin holes should be protected.
- Handle painting process shouldn't exceed 200°C and 15 min.

KALE LUNA ALÜMİNYUM Ç.A. SİSTEMİ
KALE LUNA ALUMINIUM T&T SYSTEM

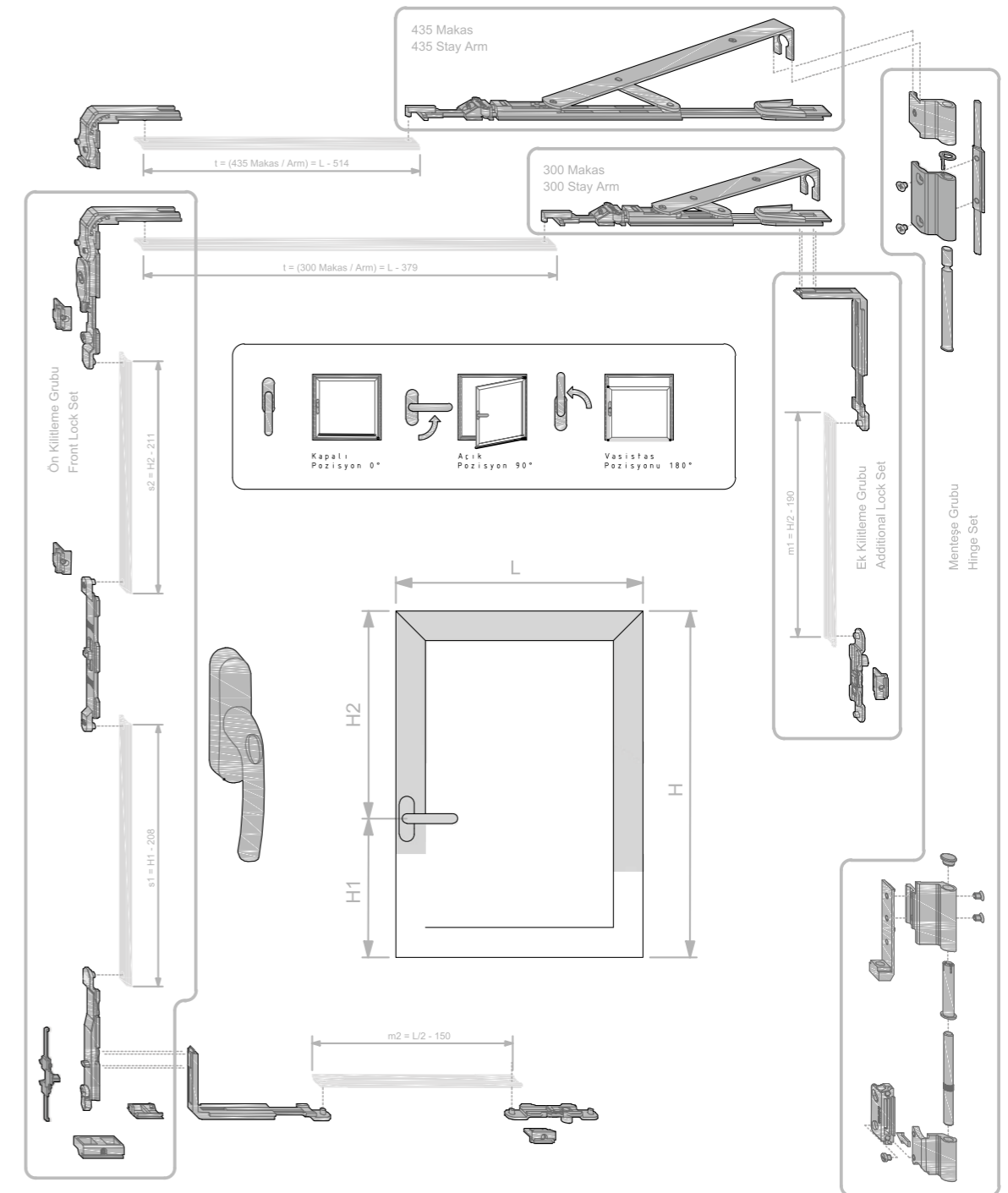



BEYAZ | GRİ | SİYAH | A.MEŞE | K.KAHVE | KREM

08 030100

ANTİ-BAKTR.SİLİKON
ŞEFFAF 310ML



BEYAZ | GRİ | SİYAH | A.MEŞE | K.KAHVE

08 050121

SODAL ACRYRUB SİLİKONİZE
MASTİK BEYAZ 500 GR



BEYAZ | GRİ | SİYAH | KAHVE

08 040210

WACKER GM CEPHE
SİLİKONU ŞEFFAF

08 050150

290 ML SODAL FIX ALL
TURBO BEYAZ

08 060103

POLİÜRETAN KÖPÜK
750 ML

08 060104

TABANCALI KÖPÜK
750 ML

08 060201

SPREY
TABANCA TEMİZLEYİCİ

08 110200

COLOR SPREY
400 ML

08 010202

ST 30
KİMYASAL DUBEL

08 010203

MERMER
YAPIŞTIRICISI

08 010102

COSMOPUR 819 ALM
KÖŞE YAPIŞTIRICI



0,5MM | 1500MM | 37,5 MT

08 100301

MEBRAN
EPDM



1,0 | 50 MM | 10MT

08 100201

OL-FOILBAND



1,5 | 40MM | 40 MT

08 100102

ÇİFT TARAFLI
NORT

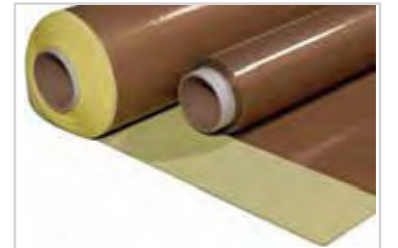
06 140900

TEFLON
YAPIŞKANLI

08 100310

MEBRAN EPDM
YAPIŞTIRICI FLEXBOND



6 MM | 9 MM | 10,5 MM | 12 MM | 14,5 MM | 15,5 MM

10 010100

6 MM BUTİLLİ
ALM. PROFİL



6 MM | 9 MM | 10,5 MM | 12 MM | 14,5 MM | 15,5 MM

10 010300

ISICAM
KLİPS

10 030100

NEM ALICI



10 MM | 15 MM | 20 MM

03 060100

DERZ DOLGU FİTLİ
10 mm x 900 mt

10 020150 | 10 020151

EKOPLAST A 30 kg
EKOPLAST B 3 kg

01 130210

 ARAKAYIT
BAĞLANTISI GENİŞ

01 130207

 ARAKAYIT
BAĞLANTISI DAR

01 130212

 C60 ORTA KAYIT
BAĞLANTI SAC

01 120205

 KELEBEK
CEPHE KARŞILIĞI

01 120200

 AYARLI İSPANYOLET
KARŞILIGI VİDALI

01 120201

 SETİZKURLU AYARLI
İSPANYOLET KARŞILIĞI

01 120101

 İSPANYOLET
PİMİ ALDOKS

01 120102

 İSPANYOLET
PİMİ ISI YALITIM

01 130305

 Y.S ALYAN
BAĞLANTI

01 130322

 L ORTAKAYIT
BAĞLANTISI

01 130314

 FUJİ 2000
ZAMAK BAĞLANTI

01 130318

 MO 19
İNCE L KÖŞE

01 130306

 19 MM ZAMAK
KÖŞE BAĞLANTI 0423

01 130308

 24 MM ZAMAK
KÖŞE BAĞLANTI 0404

01 130307

 26 MM ZAMAK
KÖŞE BAĞLANTI 0365

01 130313

 MO 42.00490
ZAMAK DAR BAĞLANTI

01 130325

 MO 43 ZAMAK BAĞLANTI
0326 41.4x38.4

01 100601

 PLASTİK YATAY
BAĞLANTI APARATI

80 LİK | 100 LÜK | 120 LİK | 150 LİK

01 100106

L ANKRAJ

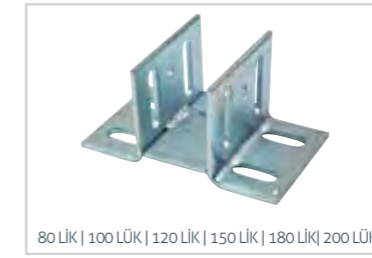

80 LİK | 100 LÜK | 120 LİK | 150 LİK | 180 LİK | 200 LÜK

01 100121

U ANKRAJ



01 100100

100 LUK F ANKRAJ

03 090150

 GENLEŞME
LASTİĞİ

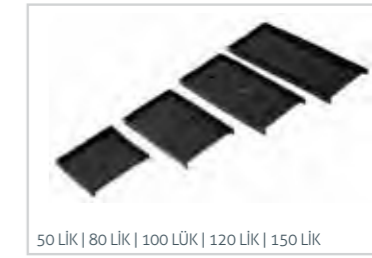
01 100600

 PLASTİK KASET ALTI
TAKOZU

50 LİK | 80 LİK | 100 LÜK | 120 LİK | 150 LİK

01 100500

 GENLEŞME
LASTİĞİ-YAKA



KG-1 / KG-2 / KG-3

01 100501

KIRLANGIÇ
GEÇME YAKASI



01 110200

WD-37
KENET KAPAĞI



01 110250

IZO WD 70
ADAPTÖR KAPAĞI



01 110251

IZO WD 59
ADAPTÖR KAPAĞI



01 110221

MO 37
ADAPTÖR KAPAĞI



01 110240

1791-1726-1727
ADAPTÖR KAPAĞI



01 110201

S-28
KENET KAPAĞI

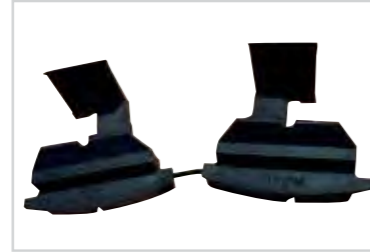

01 110226

MO 97
ADAPTÖR KAPAĞI



01 110216

MO 23
ADAPTÖR KAPAĞI



01 130316

MO 20
PLS KÖŞE



01 071023

IZO SÜRME
ÇAVUŞ PLASTİK



01 071024

IZO SÜRME TOZLUK
PLASTİK



01 071025

İZO SÜRME
KANAT PLASTİĞİ



01 071020

İZO SÜRME RULMAN
PLASTİK



01 071021

İZO SÜRME
STOPERİ PLASTİK



01 150200

ALÜMİNYUM
KAPI ALTI FIRÇASI 90 CM



01 150201

ALÜMİNYUM
YAN KAPI ALTI FIRÇASI 90 CM



01 150202

ALÜMİNYUM
KAPI ALTI FIRÇA 1 MT





01 110301

SKS 99 C
SÜRME KAPI SİSTEMİ



01 110128

CAM CAMA
RULMAN



01 110107

TUBA
MAKARA SARI



01 110112

TUBA
MAKARA ÇİFTLİ SARI



01 110117

TUBA
MAKARA PLASTİK



01 110122

TUBA
MAKARA ÇİFTLİ PLASTİK



01 110139

MS 0102
TEKLİ MAKARA AYARLI



01 110134

MS 0201
ÇİFTLİ MAKARA AYARLI

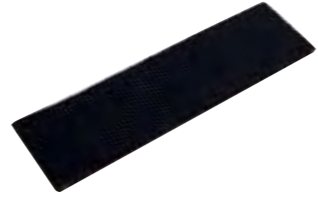

**06 140100**2,5x2
MİNİK CAM TAKOZU**06 140207**3,5x2 MM
ISI CAM TAKOZU**06 140200**2x20x80
İNCE CAM TAKOZU**06 140203**3x20x80
ORTA CAM TAKOZU**06 140208**5x20x80
KALIN CAM TAKOZU

BEYAZ | AÇIK KAHVE | KOYU KAHVE | SİYAH | GRİ

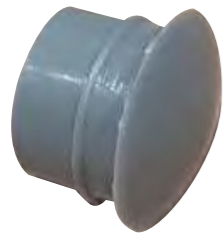
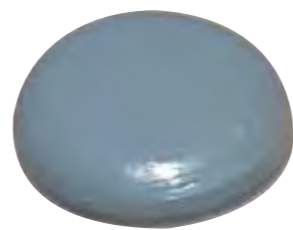
04 010114İSPANYOLET
KARŞILIĞI PLASTİK**04 010108**12 MM
PLASTİK TAPA**04 010109**VİDA
TAPASI**04 010110**BULDEX
VİDA TAPASI**04 010111**TAHLİYE TAPASI
PLASTİK**06 140299**AYAR
PENSESİ

18 MM | 24 MM | 28 MM | 32 MM

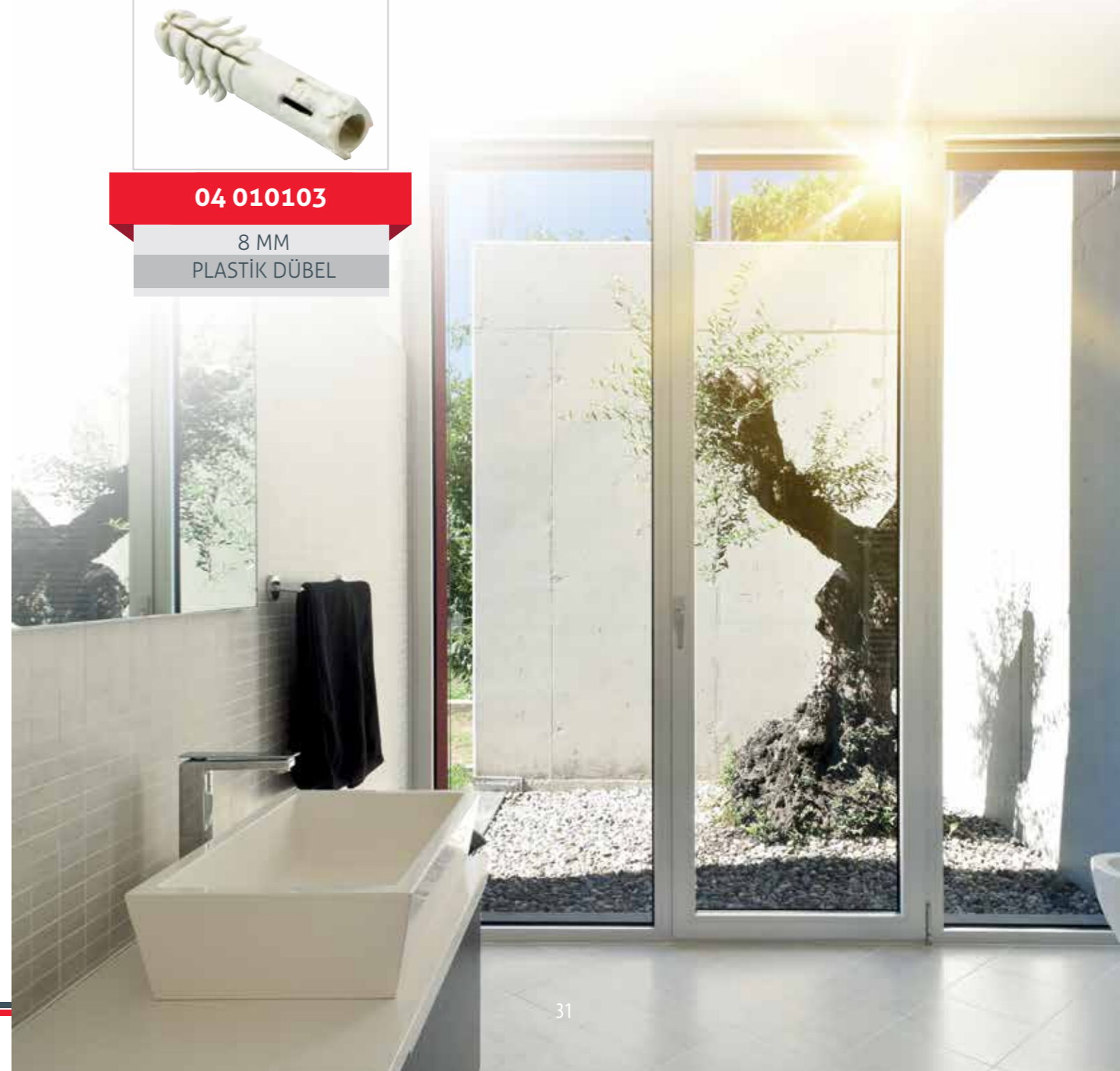
06 140300AYARLI
CAM TAKOZU**01 140101**CAM BİNECEĞİ
METAL**01 140126**AK-903
ÜÇAYAK KÖŞE.**01 140114**SİGMA
BAĞLANTI**04 010103**8 MM
PLASTİK DÜBEL



BEYAZ | AÇIK KAHVE | KOYU KAHVE | GRİ | SİYAH

04 105006

5006 PLS
KÖŞE TAKOZU 17x25



BEYAZ | AÇIK KAHVE | KOYU KAHVE | GRİ | SİYAH

04 105003

5003
KÖŞE TAKOZU 10x20



BEYAZ | AÇIK KAHVE | KOYU KAHVE | GRİ | SİYAH

04 105009

5009 PLS
KÖŞE TAKOZU 20x40



BEYAZ+AÇIK KAHVE+KOYU KAHVE+GRİ+SİYAH

04 105010

5010 PLS
KÖŞE TAKOZU 17x42



BEYAZ+AÇIK KAHVE+KOYU KAHVE+GRİ+SİYAH

04 105007

5007 PLS KÖŞE TAKOZU
45° 17x25



BEYAZ+AÇIK KAHVE+KOYU KAHVE+GRİ+SİYAH

04 105004

5004 KÖŞE TAKOZU
10x20



BEYAZ+AÇIK KAHVE+KOYU KAHVE+GRİ+SİYAH

04 105001

5001 PLS MENTEŞE
17x25



BEYAZ+AÇIK KAHVE+KOYU KAHVE+GRİ+SİYAH

04 105002

5001 PLS MENTEŞE
10x20



BEYAZ+AÇIK KAHVE+KOYU KAHVE+GRİ+SİYAH

04 105052

5052 PLS ÇIT ÇIT
17x25



BEYAZ+AÇIK KAHVE+KOYU KAHVE+GRİ+SİYAH

04 105053

5053 PLS ÇIT ÇIT
10x20



BEYAZ+AÇIK KAHVE+KOYU KAHVE+GRİ+SİYAH

04 105014

5014 PLS TUTMA KOLU
17x25



BEYAZ+AÇIK KAHVE+KOYU KAHVE+GRİ+SİYAH

04 105015

5015 PLS TUTMA KOLU
17x25



BEYAZ | AÇIK KAHVE | KOYU KAHVE | GRİ | SİYAH

04 105016

5016 PLS TUTMA KOLU
10x20



BEYAZ | AÇIK KAHVE | KOYU KAHVE | GRİ | SİYAH

04 105012

5012 PLS KÖŞE TAKOZU
(TAKVİYE)



BEYAZ | AÇIK KAHVE | KOYU KAHVE | GRİ | SİYAH

04 105013

5013 PLS
D KOL



BEYAZ+AÇIK KAHVE+KOYU KAHVE+GRİ+SİYAH

04 105018

SÜRME
HAVUZ KOL



BEYAZ+AÇIK KAHVE+KOYU KAHVE+GRİ+SİYAH

04 105023

BYZ BAĞLAMA PABUCU
17x25 - 10x20



BEYAZ+AÇIK KAHVE+KOYU KAHVE+GRİ+SİYAH

04 100100

SİNEKLİK MIKNATISLI
ÇIT ÇIT

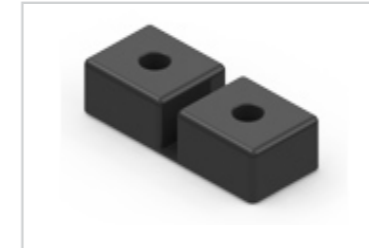
04 105055

ARA KAYIT
BAĞLANTI ELEMANI

04 105024

PASLANMAZ
TIRNAK SETİ



BEYAZ+SİYAH

03 020115

SİNEKLİK FİTİLİ
5 MM

04 105007

PLS FİTİL TAKMA
APARATI

04 044005

SÜRME SİNEKLİK
RULMANI

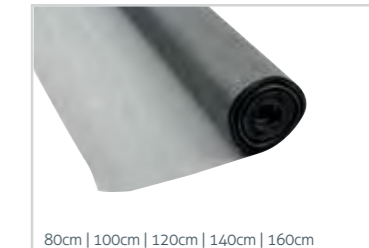

80cm | 100cm | 120cm | 140cm | 160cm

04 060080

SİNEKLİK TÜLLERİ

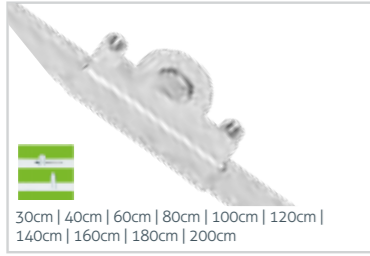
06 010200

 PVC DÜZ
İSPANYOLET

06 010300

 PVC GÖBEKLİ
İSPANYOLET

06 010500

 KİLİTLİ KAPI
İSPANYOLET

06 020102

 75 MM ZAMAK
KANAT MENTEŞESİ

06 020502

 100 MM ZAMAK
KAPI MENTEŞESİ

06 070102

 ALM.
KİLİTLİ KAPI KOLU

06 070802

 PINAR 85 MM
EKSEN YAYLI

06 070602

 PINAR WC
KAPI KOLU

06 140407

 ELİT
EMNİYET MANDALI (EKO)

06 060402

 ALM.
KİLİTLİ PENCERE KOLU

06 060602

 ALM.LÜKS
PINAR PEN.KOLU

06 140403

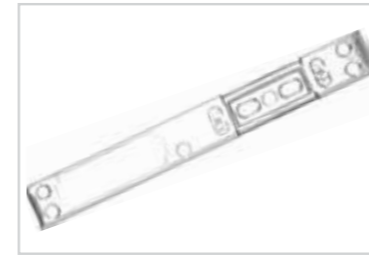
 ELİT
EMNİYET MANDALI KİLİTLİ

06 140600

 AYARLI KİLİT KARŞILIĞI
UNI UZUN

06 140601

 AYARLI KİLİT KARŞILIĞI
UNI KISA

06 150506

 SÜRME İSPANYOLET
KARŞILIĞI SAC

06 140702

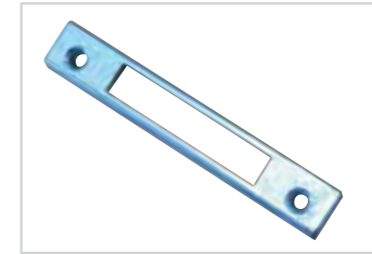
 KİLİTLİ
İSP KARŞILIĞI ST-1

06 140703

 KİLİTLİ
İSP KARŞILIĞI ST-2

06 140500

 ZAMAK ÇİFT
KANAT SÜRGÜSÜ

06 140503

SAC KAPI SÜRGÜ

06 140502

SAC KANAT SÜRGÜ

06 150503

 SÜRME RULMAN
PRİNÇ BÜYÜK

06 150202

SÜRME GÖMME KOL

06 150402

 GÖMME BÜYÜK TUTAMAK
BEYAZ



06 120702

SAC VASİSTAS MAKAS
13 CM BEYAZ



06 120802

SAC VASİSTAS MAKAS
22 CM BEYAZ



06 120405

ÇELİK MAKAS (PVC)



06 120302

PVC VASİSTAS
ÇARPMA BEYAZ



06 120900

BALKON
KAPI ÇIT ÇITI



06 050127

ZAMAK ISP. KARŞILIĞI
PAKPEN



06 050103

ZAMAK KARŞILIK/
PİMAPEN 6000

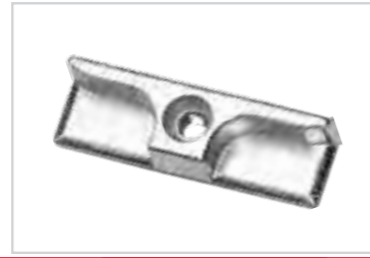

06 050120

ZAMAK ISP.KARS.
FIRAT TEK



06 140816

RÖTUŞ KALEMİ
ALTIN MEŞE+ MAUN

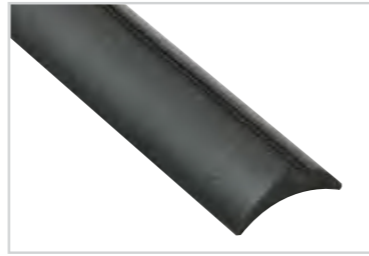
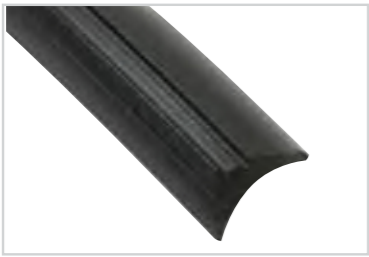
**03 020501**HORTUMLU CAM FİTİLİ
6 MM (100 MT)**03 020502**HORTUMLU CAM FİTİLİ
4 MM (100 MT)**03 020503**HORTUMLU CAM FİTİLİ
3 MM (100 MT)**03 020209**EPDM ALDOKS
KANAT CONTASI 0244 (100mt)**03 020208**EPDM ALDOKS KASA
CONTASI 4914 (100mt)**03 020401**ALDOKS GENİŞ FİTİL
(100mt)**03 020210**EPDM C 60 KANAT CONTASI
2001 (150 MT)**03 020705**C 60 KANAT FİTİL
(100 MT)**03 070106**EPDM LASTİK CONTA 2319
(2mm KAMA FİTİLİ 250mt)**03 070103**EPDM LASTİK CONTASI 2300
(3mm KAMA FİTİLİ 180mt)**03 070101**EPDM LASTİK CONTASI 2209
(4mm KAMA FİTİLİ 145mt)**03 070105**EPDM CONTA 2210
(5mm KAMA FİTİLİ 140mt)**03 015517**EPDM CONTA 5517
(6mm KAMA FİTİLİ 110mt)**03 080100**MO 60 PVC
OMEGA FİTİL (100 mt)**03 080101**MO 68 PVC EPİL
82 FİTİL (100 mt)



KD002 / 30-220 | 50-330 | 50-400 | 50-440 | 50-550

11 030300

KD002/30-220
KALE KAPI HİDROLİĞİ (GRİ)



KD002 / 40-330 | 40-440

11 030313

KD002/40-330 KALE
KAPI HİDROLİĞİ PASL.RAYLI



KD070 / 12-100

11 030400

KD-070/12-100
KALE CAM DETAY



KD070 / 12-200

11 030401

KD-070/12-200
KALE STANDART DETAY



KD 20-105

11 030403

KD-070 20-105
KALE ALÜMİNYUM DETAY



KD070 / 40-100 | 40-102 | 40-104 | 40-105
40-106 | 40-107 | 40-108

01 031610

KD-070 / 40-100
KALE H KOL



11 030500

CAM DETAY AKSESUAR+
STANDART DETAY AKSESUAR
ALM. DETAY AKSESUAR



DORMA TS71 | TS72 | TS77 | TS89 | TS90 | TS91 | TS92 | TS93

11 030103

DORMA TS 71
KAYAR KOL KAP. POM



DORMA BTS75 | BTS80 | BTS84

11 030205

DORMA GÖMME
KAPI POMPALARI



GEZE TS1000 | TS1500 | TS2000 | TS3000 | TS4000 | TS5000

11 030601

GEZE TS 1000
KAPI POMPASI GRİ



BEVAZ+ GRİ

11 031021

VARIA 230V
GRİ YÜKSEK AÇILIM

HSS MATKAP UÇLARI



- 11 020099: 2,5 MM HSS MATKAP UCU
- 11 021000: 3,0 MM HSS MATKAP UCU
- 11 021023: 3,5 MM HSS MATKAP UCU
- 11 021002: 4,0 MM HSS MATKAP UCU
- 11 021004: 4,2 MM HSS MATKAP UCU
- 11 021005: 4,5 MM HSS MATKAP UCU
- 11 021006: 5,0 MM HSS MATKAP UCU
- 11 021007: 5,5 MM HSS MATKAP UCU
- 11 021008: 6,0 MM HSS MATKAP UCU
- 11 021009: 7,0 MM HSS MATKAP UCU
- 11 021010: 8,0 MM HSS MATKAP UCU
- 11 021011: 10 MM HSS MATKAP UCU
- 11 021012: 12 MM HSS MATKAP UCU

SDS MATKAP UÇLARI



- 11 021400: SDS MATKAP UCU 6x210 MM
- 11 021410: SDS MATKAP UCU 6x260 MM
- 11 021401: SDS MATKAP UCU 7x210 MM
- 11 021412: SDS MATKAP UCU 7x260 MM
- 11 021402: SDS MATKAP UCU 8x210 MM
- 11 021403: SDS MATKAP UCU 10x210 MM
- 11 021404: SDS MATKAP UCU 12x210 MM
- 11 021405: SDS MATKAP UCU 14x200 MM
- 11 021406: SDS MATKAP UCU 16x200 MM
- 11 021407: SDS MATKAP UCU 18x200 MM
- 11 021408: SDS MATKAP UCU 20x200 MM

YILDIZ MATKAP UÇLARI



- 11 020600: PH2 25 MM YILDIZ UC
- 11 020601: PH2 50 MM YILDIZ UC
- 11 020602: PH2 75 MM YILDIZ UC
- 11 020603: PH2 100 MM YILDIZ UC
- 11 020604: PH2 150 MM YILDIZ UC

- 11 020950: BOSCH PH2-49 SIKMA UCU
- 11 020951: BOSCH PH2-89 SIKMA UCU

FREZE UÇLARI

- 11 020300: 5x13/60x8 mm FREZE UCU
- 11 020320: 5x18x35x/80x8 mm FREZE UCU
- 11 020330: 5x25x55x100 mm FREZE UCU
- 11 020310: 5x14x75x120 mm FREZE UCU

11 020400-500

ALUCOBAND
ELMAS - HAVA ÇELİĞİ
FREZE UCU

11 020910

MIKNATISLI
UÇ ADAPTÖRÜ

FREUD ELMAS TESTERELER

- 02 060101: ELMAS TESTERE 200x2.8x64
- 02 060102: FREUD ELMAS TESTERE 250x2.8x80
- 02 060103: FREUD ELMAS TESTERE 300x3.0x96
- 02 060104: FREUD ELMAS TESTERE 350x3.5x120
- 02 060105: FREUD ELMAS TESTERE 400x4x30
- 02 060106: FREUD ELMAS TESTERE 420x4x30
- 02 060107: FREUD ELMAS TESTERE 450x4x128
- 02 060108: FREUD ELMAS TESTERE 500x4x120

PİLANA ELMAS TESTERELER

- 02 070104: PİLANA ELMAS TESTERE 300x3.2x30 96
- 02 070105: PİLANA ELMAS TESTERE 400x3.6x30 120
- 02 070106: PİLANA ELMAS TESTERE 250x3.2x30 80
- 02 070107: PİLANA ELMAS TESTERE 350x3.6x30 108
- 02 070109: PİLANA ELMAS TESTERE 420x3.6x30x120
- 02 070108: PİLANA ELMAS TESTERE 450x4,0x30x108
- 02 070110: PİLANA ELMAS TESTERE 500x4,5x3,5x32 Z 120
- 02 070111: PİLANA ELMAS TESTERE 550x4,4x30x120

02 070200

ALUCOBANT
DAİRE BIÇAĞI

02 080100

KÖNİG
ELMAS TESTERE

02 010900

ALÜMİNYUM
KERTME BIÇAĞI 3'lü



Ambalaj içeriği:
Derinlik mesnedi, Yan sap

Mutlaka derinlik mesnedi ile kullanınız.

Sürekli akım girişi	680 W
Kapasite	Beton :16 mm Çelik :13 mm Ahşap :30 mm
Boşta devir	0-2.800 devir/dk
Net ağırlık	2 kg
Akım	3.1 Ah
Mandren	1/2"

HP1641
HP1641K
HP1641 / HP1641K

HP1641K



Sürekli akım girişi	450 W
Kapasite	Çelik :10 mm Ahşap :25 mm
Boşta devir	0-3.400 devir/dk
Net ağırlık	1.3 kg
Akım	2.0 Ah
Mandren	3/8"

6413

Ambalaj içeriği:
Derinlik mesnedi,
Otomatik mandren
Yan sap,



HR2470T ile verilir

Sürekli akım girişi	780 W
Kapasite	Buata :65 mm Beton :24 mm Çelik :13 mm Ahşap :32 mm
Boşta Devir	0-1.100 devir/dk
Net ağırlık	2.8 kg
Akım	3.5 Ah
Darbe Enerjisi	Deney Sonucu 2.7 J EPTA Değeri 2.4 J

Mutlaka derinlik mesnedi ile kullanınız.

HR2470T (24mm)

(115mm)



Kontrollü çalışma sistemi

Ambalaj içeriği: Yan sap, Siper Aşındırıcı taş, Anahtar

Sürekli akım girişi	720 W
Kapasite	Kesici/aşındırıcı/elmas
	115mm
Boşta devir	11.000 devir/dk
Mil çapı	M14
Net ağırlık	1.8kg
Akım	3.2 Ah

GA4530R

HP1641K



Ambalaj içeriği: Yan sap, Siper, Anahtar

Sürekli akım girişi	2200 W
Boşta devir	GA7020: 8.500 devir/dk GA9020: 6.600 devir/dk
Mil çapı	M14
Net ağırlık	5.5/5.8kg
Akım	10 Ah

GA7020 (180mm) | GA9020 (230mm)

Kapasite	Çelik: 10 mm Ahşap: 25 mm Ahşap vida: 6 mm x 75 mm
Boşta devir	0-400/1.300 d/d
Maksimum tork	18/30 N.m
Net ağırlık	1.4kg
Güç kapasite	12V/1.3Ah/Ni-Cd
Akü / Şarj cihazı	PA12 / DC1414T
Mandren	3/8"

6271DWPLE



Sürekli akım girişi	900 W
Kapasite	Uç tutucu: 8mm
Dalma kapasitesi	0-35mm
Boşta devir	27.000 devir/dk
Net ağırlık	2.6kg
Akım	4.1Ah

Ambalaj İçeriği: Kenar gönye, Anahtarlar, Şablon Kılavuzu, Toz Kapağı

RP0900

Sürekli akım girişi	2000W
Kapasite	90° : 85mm 45° : 60mm
Testere ölçüleri	235 x 2.3 x 30mm
Boşta devir	4.100 devir/dk
Net ağırlık	7.0kg
Akım	9.2 Ah

Ambalaj İçeriği: Daire testere, Kenar gönye, Allen anahtar

N5900B

Sürekli akım girişi	450W
Kapasite Ahşap	90° : 65mm
Çelik	90° : 6mm
Vargel uzunluğu	18mm
Vargel sayısı	500-3.100 devir/dk
Net ağırlık	1.9kg
Akım	2.1Ah

Ambalaj İçeriği: Bıçak, Allen anahtar

4327 (Devir ayarlı)

Sürekli akım girişi	710 W
Kapasite	Beton : 16 mm Çelik : 13 mm Ahşap : 30 mm
Boşta devir	0-3.200 devir/dk
Net ağırlık	2 kg
Akım	3.2 Ah
Mandren	1/2

Mutlaka derinlik mesnedi ile kullanınız.

HP1631 | HP1631K

Sürekli akım girişi	1300W
Kapasite	90° : 56mm 45° : 40mm 48° : 38mm
Testere ölçüleri	165 x 2.2 x 20mm
Boşta devir	2.000-5.800 d/d
Net ağırlık	4.4kg
Akım	5.9Ah

Ambalaj İçeriği: Daire testere, Kenar gönye, Allen anahtar

SP6000J (Devir ayarlı)

Sağ-Sol	
Uzunluk	: 177 mm
Mandren Kap.	: 10 mm
Mandren Ba..	: 3/8 24 UNF
Boşta Devir	: 1800 rpm
Hortum Çapı	: 10 mm
Hava Giriş Nipeli	: 1/4"
Hava Tüketimi	: 270 lt/dk
Çalışma Basıncı	: 90 psi (6.2 atü)
Ağırlık	: 1,30 kg

OPT 232 10MM MATKAP OSAKA
11 080400



Uzunluk	: 170 mm
Pens Çapı	: 6 mm
Taş Çapı	: 38.00 mm
Boşta Devir	: 22,000 rpm
Hortum Çapı	: 9.5 mm
Hava Giriş Nipeli	: 1/4"
Hava Tüketimi	: 185 lt/dk
Çalışma Basıncı	: 90 psi(6.2 atü)
Ağırlık	: 0,74 kg

OPT 127 KALIPÇI TAŞLAMA OSAKA
11 080430

25 mt | 35 mt | 50 mt

11 150100

 GRS013 3X1,5MM 25MT
MONO SARAÇ

11 220104

 TOMAX
ISKARPELA 20

11 120106

 SİLİKON TABANCASI
İSKELET

11 080105

 OPT 3042 FRL
OSAKA ŞARTLANDIRICI 1/2'

11 080100

 HAVA TABANCASI
KISA

11 120203

 SOUDAL PU
KÖPÜK TABANCASI-PLASTİK

11 050107

 SU TERAZİSİ
100 CM

11 200200

UFAK İŞKENCE

11 130202

 DEMİR
TESTERE KOLU

11 080103

 SİRAL
HAVA HORTUMU 15 MT

11 020503

 GRANİT
MERMER PANÇ 20 MM

11 140211

 115x1,0x22 DÜZ
İNOX KESİCİ DİSK KARBOSAN

11 050102

 MIKNATISLI HON
SU TERAZİSİ 80 CM

11 030205

 FİSCO
METRE UM 3

16 MM | 20 MM

09 070102

 PANJUR KORDONU
GENİŞ



11 060201

FISCO
METRE UM 5



11 170100

SILBERTHSCHNT
CAM KESME ELMASI



11 160101

2 Lİ METAL CAM VANTUZ
80 KG



11 240102

KARGABURUN
160 MM



08 070102

HIZLI YAPIŞTIRICI JAPON
20 GR



11 240101

YAN KESKİ
160 MM



11 170208

GAZLI CAM KESER
METAL



11 130104

HON MAKET BIÇAĞI
METAL



11 160102

3 LÜ METAL CAM VANTUZ
120 KG



11 100106

ANCHOR
YARIM YUVARLA EĞE 8 MM



11 100100

ANCHOR
EĞE 6 MM HAND KALIN



11 240100

KOMBİNE PENSE
6*180 MM



11 130204

FİTİL KESME MAKASI
JBM



11 210100

PERÇİN TABANCASI
TOMAX



04 030133

PLS CONTA
ÇEKME MAKARASI

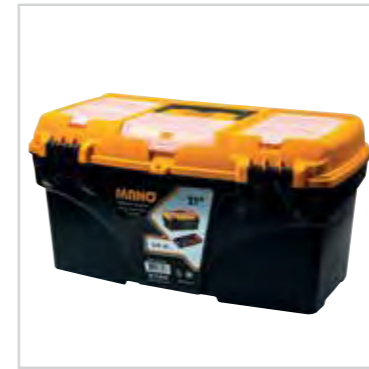

11 230102

MANO 21 LİK
TAKIM ÇANTASI



11 050104

SU TERAZİSİ
MİNİ 25cm

11 240103

 RONEY
İŞ ELDİVENİ KIRMIZI

11 110201

 2+2,5+3+4+5+6+MM
L ALLEN ANAHTAR

11 110210

 ALLEN
ANAHTAR TAKIMI

11 090205

 8x150
YILDIZ TORNAVİDA

11 090105

 8x150
DÜZ UÇLU TORNAVİDA

11 220100

 PVC YÜZEY TEMİZLEME
EL ALETİ NİS 01

 Portatif Mekanik, Ø300mm, 230V,
TESTERESİZ

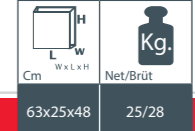
 Standart Aksesuarlar
• Profil dayama
• 1x yatay mengene

KD 305 (Dereceli Kesme Makinesi)

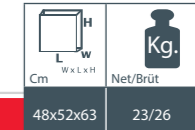
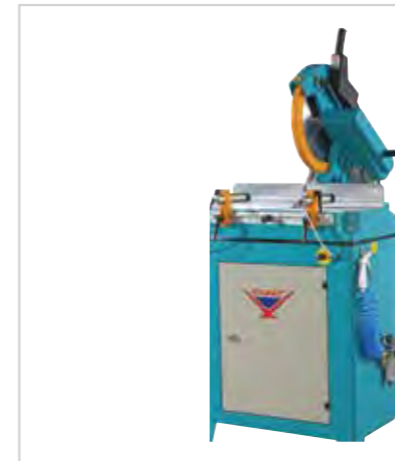
 Yatarlı, Portatif, Mekanik, Ø300mm,
230V,
TESTERESİZ

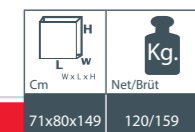
 Standart Aksesuarlar
• Profil dayama
• 1x yatay mengene

KY 310 (Dereceli Kesme Makinesi YENİ)

 Pnömatik Mengene, Sehpalı, Ø400 mm
TESTERELİ, 400V

 Standart Aksesuarlar
• Ø 400 mm testere
• 2 x pnömatik yatay mengene

KD 400 P (Dereceli Kesme Makinesi)



Portatif Manuel,
Mekanik Mengeneli, 230V
Bıçaksız

- Standart Aksesuarlar
- 1x manuel dikey mengine
 - 1x manuel yatay mengine

Cm L x W x H	Net/Brüt Kg.
63x25x48	25/28

KM 212 (Orta Kayıt Alıştırma Makinesi)

Otomatik, Ölçü Alma Aparatlı,
Özel Kalıp Sistemli,
400V

Standart Aksesuarlar

- 1x Ø 200 ve 1x Ø 110 mm testere
- KN 152 konveyör
- Hava tabancası

Cm L x W x H	Net/Brüt Kg.
54x113x124	134/168

CK 412 (PVC Çıta Kesme Makinesi)

Yarı Otomatik, Pnömatik Mengeneli,
Açı Ayarlı, Seri Bıçak Değiştirmeli
(230V- 400V) Bıçaksız

- Standart Aksesuarlar
- 1 x pnömatik dikey mengine
 - 1 x pnömatik yatay mengine
 - Hava tabancası

Cm L x W x H	Net/Brüt Kg.
55x95x127	90/119

KM 215 (Orta Kayıt Alıştırma Makinesi)

30-180°Açılı,
180mm kaynak yüksekliği,
0.2 mm - 2mm Kaynak Özelliği,
230V

Cm L x W x H	Net/Brüt Kg.
84x84x154	163/207

TK 505 (PVC Tek Köşe Kaynak Makinesi)

Portatif Mekanik, 230V

- Standart Aksesuarlar
- Ø5 freze ucu
 - 2x sol ve sağ profil dayama
 - 2x yatay manuel mengine

Cm L x W x H	Net/Brüt Kg.
53x60,5x48,5	26/29

FR 222 (Kopya Freze Makinesi)

Kompozit Panel İşleme Merkezi *
1600 x 6650mm
Net İşleme Ölçüsü,
CNC Kontrol,
Çift İstasyon Çalışma,
Otomatik Vakum Kontrollü

Cm L x W x H	Net/Brüt Kg.
730x235x180	2661/2965

CPM 6161



PVC Üçlü Kol Yeri Delmeli - Otomatik,
900 D/dak., 400V

Standart Aksesuarlar

- Ø5 Freze ucu
- Profil dayama
- 2x Yatay mengene pnömatik
- Hava tabancası

Cm L W x L x H	Net/Brüt Kg.
64x80x 149	105/147

FR 226 (Kopya Freze Makinesi)

Yarı Otomatik, Hidro-Pnömatik,
Ø420 mm Testere, 3 metre konveyörlü,
Soğutmalı, 400V

Standart Aksesuarlar

- Ø 420 mm testere
- MKN 300 konveyör (3 m)
- 2 x dikey mengene
- Püskürtmeli soğutma sistemi
- Hava tabancası

Cm L W x L x H	Net/Brüt Kg.
95x95x149	210/260

ACK 420 S

Alüminyum Köşe Birleştirme Presi
Hidrolik Pres, 400V

Standart Aksesuarlar

- 2x3 mm, 2x5 mm ve 2x7 mm genişlikte presleme bıçakları
- 2x pnömatik dikey mengene
- 2x profil destek kolu
- 2x alyan anahtar (4 ve 5 mm)

Cm L W x L x H	Net/Brüt Kg.
100x116x 140	457/504

KP 120 (Alttan Çıkma Kesme Makinesi)

Manuel Panç Pres
Yuvarlak, Ø 12 mm

Cm L W x L x H	Net/Brüt Kg.
22x23x35	6

PY 100

Manuel Panç Pres
Dikdörtgen

Cm L W x L x H	Net/Brüt Kg.
22x23x35	8

PY 101

Manuel Panç Pres
Yuvarlak Çift Zımbalı

Cm L W x L x H	Net/Brüt Kg.
22x23x35	8

PY 102

Manuel Panç Pres
Sigma, Ø 11 mm

Cm L W x L x H	Net/Brüt Kg.
22x23x35	8

PY 104

Manuel Panç Pres
Köşe Delme Presi

Cm L W x L x H	Net/Brüt Kg.
22x23x35	8

PY 106

**ÖZELLİKLER**

- Alüminyum, plastik ve ahşap profillerin kesim işlemleri için kullanılır.
- Çift yay sistemi ve testere muhafazası ile emniyetli kesim
- Üst tablada kesim
- -45° ve +45° arasında istenen tüm açılarda kesim
- Sağa ve sola 0°, 15°, 22,5°, 30°, 45° açı sabitleme

Standart Ekipmanlar

- Profil dayama

Opsiyonel Ekipmanlar

- Ø 300 mm testere
- İkinci mengene
- Konveyör, Sehpa (S - I), Fren sistemi, Trifaze sistem

ALFA (Portatif Kesim Makinesi Ø 300 mm)**ÖZELLİKLER**

- Alüminyum, plastik ve ahşap kesim işlemleri için kullanılır.
- Çift yay sistemi ve testere muhafazası ile emniyetli kesim
- Üst tablada kesim
- Sağa ve sola 0°, 15°, 22,5°, 30°, 45° açı sabitleme

Standart Ekipmanlar

- Profil dayama

Opsiyonel Ekipmanlar

- Ø 250 mm testere
- İkinci mengene
- Konveyör
- Sehpa (S - I)

ALFA MİNİ (Portatif Kesim Makinesi Ø 250 mm)**ÖZELLİKLER**

- Alüminyum, plastik ve ahşap kesim işlemleri için kullanılır.
- Çift yay sistemi ve testere muhafazası ile emniyetli kesim
- Üst tablada kesim
- -45° ve +45° arasında istenen tüm açılarda kesim
- 0° ve 45° derece sola yatan kafa (Alt tabla 0 (Sıfır) konumundayken yatarlı kesim yapar)
- Sağa ve sola 0°, 15°, 22,5°, 30°, 45° açı sabitleme

Standart Ekipmanlar

- Profil dayama

Opsiyonel Ekipmanlar

- Ø 300 mm testere, İkinci mengene
- Konveyör, Sehpa (S - I), Fren sistemi, Trifaze sistem

BETA PLUS (Portatif Yatarlı Kesim Makinesi Ø 300 mm)

ÖZELLİKLER

- Alüminyum, plastik ve ahşap profillerin kesim işlemleri için kullanılır.
- Hidro-Pnömatik kesim işlemi
- Çift yay sistemi ve testere muhafazası ile emniyetli kesim
- Pnömatik dikey ve yatay mingeneler
- Darbelere karşı dayanıklı döküm göbek
- Profile göre kesme hızını ayarlama
- -45° ve +45° arasında istenen tüm açılarda kesim
- Sağa ve sola 0°, 15°, 22,5°, 30°, 45° sabit açılarda kesim

Standart Ekipmanlar

Ø 400 mm testere

Soğutma sistemi

Opsiyonel Ekipmanlar
Konveyör, Monofaze sistem

VEGA II (Otomatik Kesim Makinesi Ø 400 mm)

ÖZELLİKLER

- Alüminyum ve plastik profillere kilit, kol yeri, menteşe, ispanyolet yuvaları ve kanal açma işlemleri için kullanılır.
- İşleme uygun kopya tertibatı
- Dayamalar yardımıyla kopya tertibatından bağımsız olarak çeşitli kanallar açma
- Pnömatik mingeneler

Standart Ekipmanlar

- 5 mm freze ucu (1 adet)
- Soğutma sistemi
- Profil dayama

Opsiyonel Ekipmanlar

- Özel kopya tertibatı
- Monofaze sistem

GALAXY I (Kopya Freze Makinesi)

ÖZELLİKLER

- Alüminyum ve plastik profillerin orta kayıt alıştırma (kertme) işlemleri için kullanılır.
- Dikey ve yatay mengene sistemi
- Ergonomik tasarımı ile kolay kullanım ve güvenli çalışma

Opsiyonel Ekipmanlar

- Kesme seti
- Sehpa (S - I)
- Trifaze sistem

POLAR I (Portatif Orta Kayıt Alıştırma Makinesi)

ÖZELLİKLER

- Alüminyum ve plastik profillere kilit, kol yeri, menteşe, ispanyolet yuvaları ve kanal açma işlemleri için kullanılır.
- İşleme uygun kopya tertibatı
- Dayamalar yardımıyla kopya tertibatından bağımsız olarak çeşitli kanallar açma
- Ergonomik tasarımı ile kolay kullanım ve güvenli çalışma

Standart Ekipmanlar

- 5 mm freze ucu (1 adet)
- Profil dayama (2 adet)

Opsiyonel Ekipmanlar

- Sehpa (S - II)
- Konveyör
- Özel kopya tertibatı

GALAXY I P (Portatif Kopya Freze Makinesi)

ÖZELLİKLER

- Alüminyum ve plastik profillerin orta kayıt alıştırma (kertme) işlemleri için kullanılır.
- Hidro-Pnömatik hareket
- Pnömatik dikey ve yatay mingeneler
- Emniyet sensörlü muhafaza ile güvenli çalışma
- İşlemin başlangıç noktasına otomatik olarak dönmesi
- Dereceli gönye ile çeşitli açılarda alıştırma işlemleri
- Kolay bıçak değiştirme
- Profil destek konveyörü
- Bıçak bekletme istasyonu
- Bıçak adaptörü

Opsiyonel Ekipmanlar

- Kesme seti, Soğutma sistemi, Monofaze sistem

POLAR IV (Otomatik Orta Kayıt Alıştırma Makinesi - Pnömatik Bıçak)

ÖZELLİKLER

- Alüminyum, plastik ve ahşap profillerin kesim işlemleri için kullanılır.
- Hidro-Pnömatik kesim işlemi
- Emniyet sensörlü muhafaza ile güvenli kesim
- Profile göre kesme hızını ayarlama
- -45° ve +45° arasında istenen tüm açılarda kesim
- Sağa ve sola 0°, 15°, 22,5°, 30°, 45° sabit açılarda kesim
- Kesme kapasitesini arttıran hareketli gönye
- Pnömatik dikey ve yatay mingeneler

Standart Ekipmanlar

- Ø 420 / 500 mm testere, Konveyör (sağ)
- Soğutma sistemi

Opsiyonel Ekipmanlar

- Konveyör, Monofaze sistem, Toz emme sistemi

METEOR-II 420 500 (Otomatik Alttan Çıkma Testere Kesim Makinesi Ø 420 / 500 mm)

ÖZELLİKLER

- Plastik profillerin çeşitli açılarda kaynak işlemleri için kullanılır. Pnömatik hareket
- 30° ve 180° arasında kaynak
- İşlemi otomatik olarak başlatma ve bitirme
- Kaynak zamanı ayarı ve dijital kontrollü ısıtma
- Elektronik termostat sayesinde 0°C - 350°C arasında sıcaklık ayarlama
- PLC kontrol sistemi

Standart Ekipmanlar

Nakliyede kolaylık sağlayan sökülebilir sehpa
Sağ ve sol profil desteği

Opsiyonel Ekipmanlar

Özel kalıp

ORION I P (Sehpalı Portatif PVC Kaynak Makinesi)

ÖZELLİKLER

- Alüminyum profillerin köşe pres işlemleri için kullanılır.
- Yüksek basınca dayanıklı çelik tabla, Hidrolik çalışma sistemi
- Ezici bıçak mesafelerini profile göre kolay ayarlama
- Gönyeler sayesinde profili otomatik merkezleme
- Merkezleme gönyesinin aşağı/yukarı hareketi ile profilin rahat çevrilmesi
- Profil işleme rahatlığı sağlayan çift taraflı yürütme ünitesi
- Geniş ve yüksek profilleri presleme
- PLC kontrol sistemi

Standart Ekipmanlar

- 7 mm ezme seti (2 adet), 5 mm ezme seti (2 adet)
- Sağ ve sol profil desteği

Opsiyonel Ekipmanlar

- Özel profiller için ezici set

APEX-I A (Otomatik Hidrolik Alttan Çıkma Gönyeli Alüminyum Köşe Presi)
ÖZELLİKLER

Kompozit panel ve levhaların derz açma ve kesim işlemleri için kullanılır. Birbirinden bağımsız 4 adet fan soğutmalı spindle motor kapasitesi, Freze ucu değişimi ile ahşap ve plastik levha işleme, Polietilen tabla üzerindeki kanallar ile ideal vakumlama, 2D CAD CAM grafik ve optimizasyon yazılımı 2,5 saniyede takım değiştime, Bağımsız bölümlerde vakumlama Otomatik freze boyu sıfırlama, Harici toz emme sistemi, NC-300A - MI CNC Kontrol Ünitesi, Otomatik pnömatik dayama sistemi Uzaktan ağ bağlantısı, Ethernet ve USB üzerinden veri aktarımı Elektrik kesintisi vb. sorunlara karşı kaldığı yerden devam edebilme özelliği, Yüklenen kod dosyasında düzenleme yapabilme özelliği, Manuel kod yazıp işleyebilme özelliği

Standart Ekipmanlar

2D CAD CAM, Freze (2 adet 4 mm kesme, 2 adet V kanal freze) Vakum pompası (700 m³/sa), Toz emme sistemi

Opsiyonel Ekipmanlar

Özel freze takımları, İsteğe bağlı uzunluk

LEPUS II (CNC Kontrollü Alüminyum Kompozit Panel İşleme Makinesi - 4 m (3 Eksen))

ÖZELLİKLER

Alüminyum profillerin 45° açı ile kesilmiş uçlarına bağlantı yuvaları açarak profillerin bu yuvalardan birleştirilmesi amacıyla kullanılır.

- Pratik işlem
- Ergonomik tasarım
- Sertleştirilmiş özel bıçak takımı

Opsiyonel Ekipmanlar

Sehpa (ARCHER SD)
Ekstra bıçak takımı

ARCHER (Portatif Alüminyum Köşe Delme Presi)

ÖZELLİKLER

- Plastik profillerin pencere çatalını 45° açılı kesme işlemleri için kullanılır.
- İşlemin başlangıç noktasına otomatik olarak dönme
- Pnömatik kesim (ORCA PP)
- Ölçü aparatlı konveyör sistemi

Standart Ekipmanlar

- Ø 100 mm testere (2 adet)
- Ø 200 mm testere (2 adet)
- Farklı ölçülerdeki profillere uyum sağlayabilen kalıp sistemi
- Çıta kalıbı
- Konveyör

Opsiyonel Ekipmanlar

- Özel kalıp

ORCA (Sehpalı Portatif PVC Çıta Kesim Makinesi)